

# SPECIFICATION

受 控

Customer : SEA  
Applied To :  
Product Name : MIC  
Model Name : KPCM-60H27A-42DB-1651  
Drawing No. : KIC1651

Signature of Appronal

--

Signature of KEPO

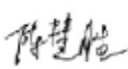
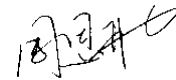
Approved by	Checkde by	Issued by	Date
			2012.05.28



宁波凯普电子有限公司

Ningbo Kepo Electronics Co.,Ltd.

宁波东钱湖镇东钱湖工业区宝源路 25 号

TEL:+86-574-88370330 FAX:+86-574-88370329

No.25 Baoyuan road Dongqian Lake, Industry Area, Dongqian town,Ningbo City,  
China(Post Code:315121)

[Sales@chinaacoustic.com](mailto:Sales@chinaacoustic.com) [www.chinaacoustic.com](http://www.chinaacoustic.com)

Specification for Microphone	Page	2/8
	Revision No.	1.0
Model No. : KPCM-60H27A-42DB-1651	Drawing No.	KIC1651

## CONTENTS

1. Scope  
1.范围
2. General  
2.概要
3. Electrical and Acoustic Characteristics.  
3.电声参数
4. Mechanical characteristics and environmental test  
4.机械特性和环境试验
5. Measurement Block Diagram & Response curve  
5.测试图和曲线图
6. Dimensions  
6.尺寸图
7. Packing  
7.包装
8. Revision  
8.履历表

# Specification for Microphone

Page 3/8

Revision No. 1.0

Model No. : KPCM-60H27A-42DB-1651

Drawing No. KIC1651

## 1. Scope 范围

This specification applies electret condenser microphone.  
此规格书适用于电容式麦克风.

## 2. General 概要

- 2.1 Out-Diameter : 6 mm
- 2.1. 外径 : 6 mm
- 2.2 Height : 2.7 mm
- 2.2. 高度 : 2.7 mm
- 2.3 Weight : ≤0.3 g
- 2.3 重量 : ≤0.3 g
- 2.4 Operating Temperature range: '-20 ~+70°C without loss of function
- 2.4 工作温度: -20 ~+70°C
- 2.5 Store Temperature range: '-20~+70°C without loss of function
- 2.5 储存温度: -20~+70°C

## 3. Electrical and Acoustic Characteristics. 电声参数

Test condition : 15 ~ 35 °C, 45% ~ 85% RH, 860~1060 mbar  
测试条件 : 15~35 °C, 45%~85%RH , 860 ~ 1060mbar

No	Items	Symbol	Unit	Specification	Condition
1	Directivity 指向性			Omni-directional 全指向性	
2	Sensitivity 灵敏度	S	dB	-42±2dB	0dB=1V/Pa,1KHz
3	StandardOperationVoltage 标准操作电压	Vs	V.D.C	2	
4	Output impedance 输出阻抗	Zout	KΩ	2.2	f=1KHz,1Pa
5	Max operating voltage 最大操作电压		V.D.C	10	
6	Sensitivity reduction 减压灵敏度	△S-Vs	dB	-3	f=1KHz,1Pa Vs=2-1.5V.D.C
7	Frequency 频率	f	Hz	100-10,000	
8	Max. Current Consumption 最大耗电电流	IDss	mA	0.5	Vs=2V,RL=2.2KΩ
9	Signal to noise ration 讯号对比杂音	S/N	dBA	60	f=1KHz,1Pa A weighted
10	Material 材质			AL 铝	
11	Terminal 端子				See appearance drawing 请参照外观尺寸图
12	Environmental Protection Regulations 环保法规			RoHS	

We use "Pascal ( Pa)" indication of sensitivity as per the recommendation of I.E.C ( International Electro technical Commission).The Sensitivity of "Pa" will increase 20dB comparing with "ubar" indication.

Example : -60dB(0dB=1v/ubar)=-40dB(1v/Pa)

依I.E.C.(国际电子协会)建议,以"Pa"为灵敏度标示单位比"ubar"灵敏度标示单位增加20dB

例如:-60dB(0dB=1V/ubar)=-40dB(1V/Pa)

# Specification for Microphone

Page 4/8

Revision No. 1.0

Model No. : KPCM-60H27A-42DB-1651

Drawing No. KIC1651

## 4.1 Mechanical Characteristics 机械特性

No.	Item	Test Condition	Evaluation standard
1	Vibration 振动试验	To be no interference in operation after vibrations. 10Hz to 50Hz for 1 minrte full amplitude 1.52mm , for 2 hours at three axes 1分钟频率变化从10Hz到50Hz,振幅在1.52mm,在三个方向测试振动2小时,产品应不受影响	After any tests,the sensitivity to be within $\pm 3\text{dB}$ 测试其灵敏度须与原测试值的差异不超过 $\pm 3\text{dB}$
2	DROP TEST 跌落测试	To be no interference in operation after dropped to concrete floor each one time from 1meterheight at three directions in state of packing 以正规包装的三个方向从1米高处自由落到混凝土地面时,产品应不受影响	

## 4.2 Environmental test 环境试验

No.	Item	Test Condition	Evaluation standard
1	High temperature test 高温测试	After being placed in a chamber at +70 °C for 72 hours. 置于+70 °C 环境中72小时.	After any tests,the sensitivity to be within $\pm 3\text{dB}$ of initial sensitivity after6H of conditioning at +25°C 经测试后麦克风,须静置于+25°C (室温) 环境中2小时后,测试其灵敏度须与原测试值的差异不超过 $\pm 3\text{dB}$
2	Low temperature test 低温试验	After being placed in a chamber at -20°C for 72 hours. 置于-20 °C 环境中72小时.	
3	Humidity Test 相对湿度试验	After being placed in a chamber at +40°C and 90-95% relative humidity for 72 hours. 置于+40°C , 相对湿度90-95%环境中72小时.	
4	Impact test 冲击试验	The width of 11ms, acceleration 150M / S <sup>2</sup> half sine pulse, 10 times in the three directions tested, sensitivity to be within $\pm 3\text{dB}$ from initial sensitivity 在宽度为11ms,加速度为150M/S <sup>2</sup> 的脉冲半正弦波,在三个方向测试10次,灵敏度偏离范围在 $\pm 3\text{dB}$	

StandardTestCondition: a)Temperature:+15°C~+35°C b)Humidity:45%-75% c)Pressure:86 kPa -106kPa

标准测试条件: a)环境温度:+15°C~+35°C b)相对湿度:45%-75% c)大气压力:86 kPa -106kPa

Judgement Test Condition: a) Temperature:(20 $\pm$ 2)°C b) Humidity:60%-70% c) Pressure:86 kPa -106kPa

判定测试条件: a) 环境温度: (20 $\pm$ 2)°C b)相对湿度: 60%-70% c)大气压力: 86 kPa -106kPa

### 5. Measurement Block Diagram & Response curve

#### 测试图和曲线图

##### 5.1 Measurement Block Diagram 测试图

Schematic Diagram  $V_s=2V$  ;  $R_L=2.2k\Omega$

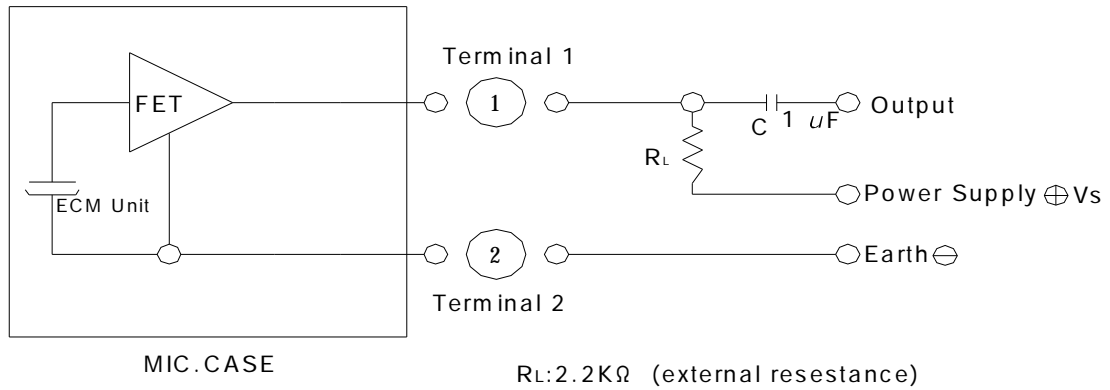

##### 5.2 Response curve 曲线图

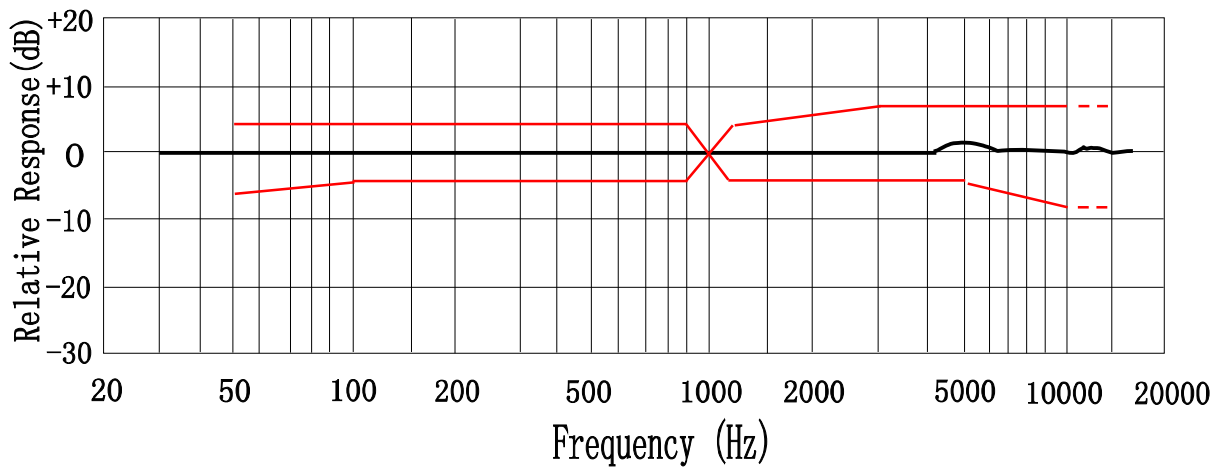

# Specification for Microphone

Page 6/8

Revision No. 1.0

Model No. : KPCM-60H27A-42DB-1651

Drawing No. KIC1651

## 6. Dimensions 尺寸图

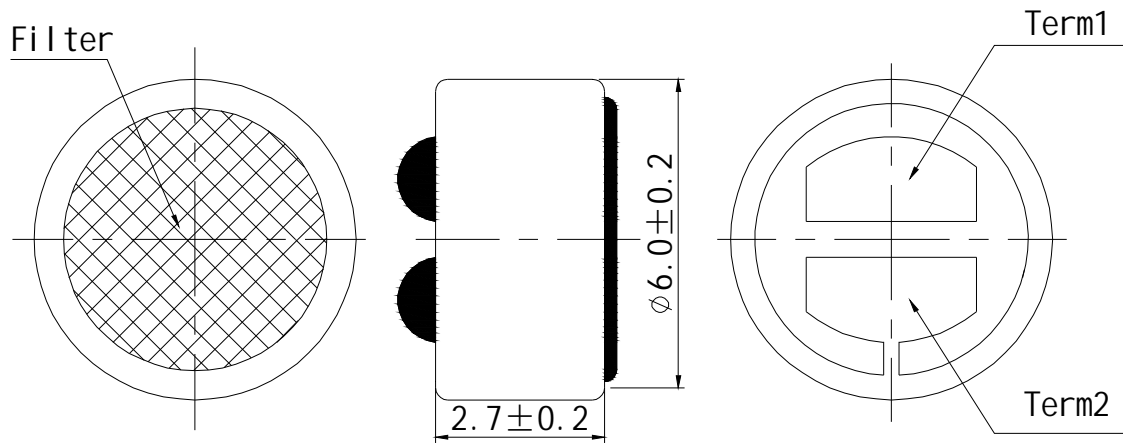

FIRST ANGLE PROJECTION

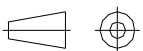

UNIT : mm

Tolerance :  $\pm 0.2$

7. Packing 包装

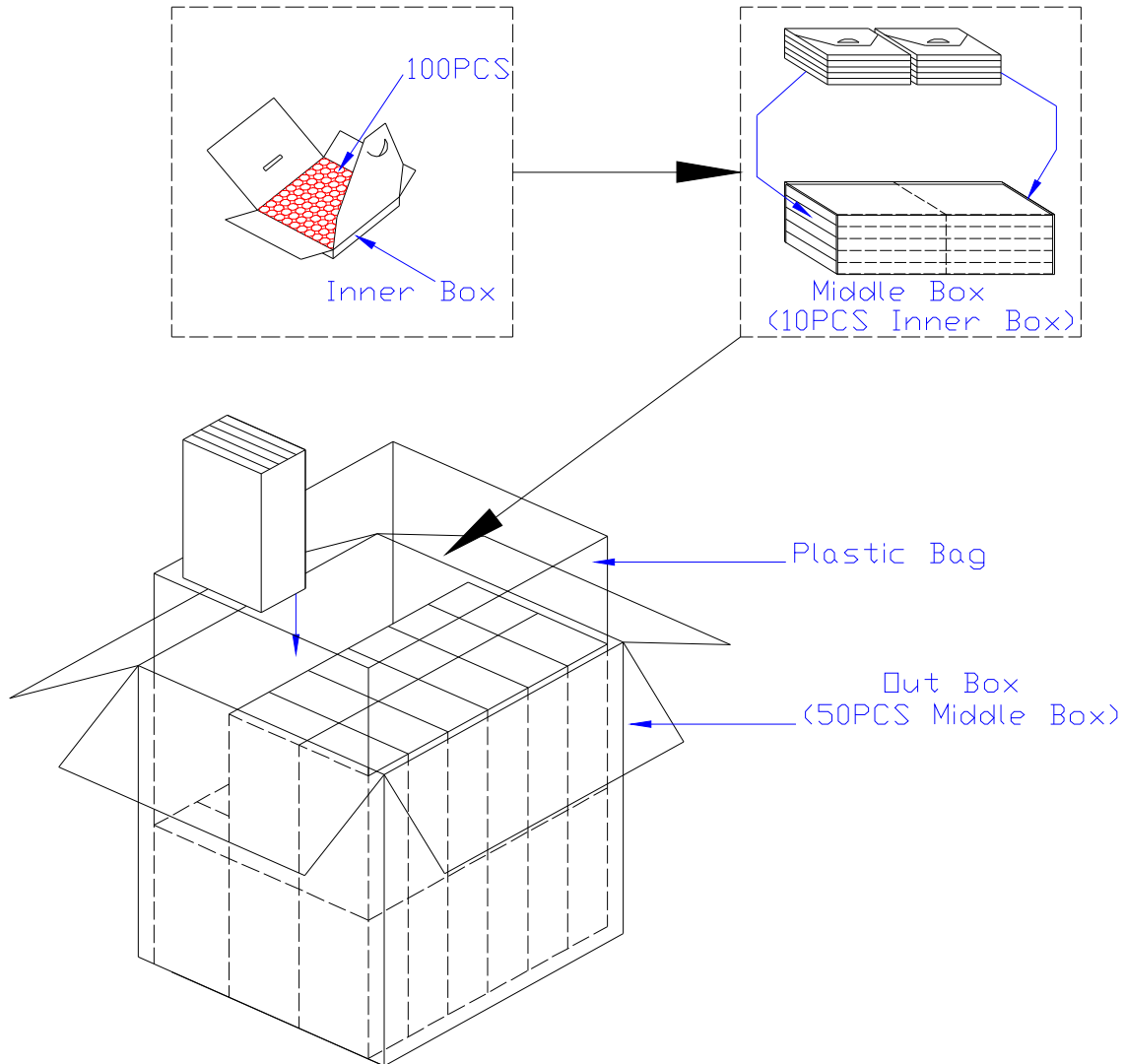

Inner Box	61mm×61mm×4mm	100PCS×1 = 100PCS
Middle Box	124mm×63mm×21mm	100PCS×10 = 1000PCS
Out Box	230mm×230mm×270mm	1000PCS×50 = 50000PCS

